



Putzmeister



MX stationary booms

Amazing artistic movements

Under its own power to the end

Achieve more with stationary booms for concrete placement

If you want to get to the top, you have to work your way up – from a solid base.

In line with this principle, MX stationary booms from Putzmeister are designed to meet all the challenges in construction.

Buildings are becoming taller and complex, and the demands placed on concrete conveying are growing alongside. This cannot always be done by truck-mounted concrete pumps, as their reaches are limited too. An effective and exceptionally cost-effective alternative is to combine Putzmeister stationary concrete pumps with static booms.

This successful combination effortlessly bridges distances and ensures targeted and very efficient concrete placement. The MX modular system, through flexible combinations of booms and sub-structure with various attachment options and self-climbing devices, allow almost limitless potentials to be utilised.



MX stationary booms offer expansion options

The application areas of stationary booms are broad and diverse. They are used just as economically for the construction of power stations, caverns, liquid gas tanks and bridges as they are on various high-rise building construction sites. They are ideally suited for integration in climbing formwork, the autonomous through-climbing of floors, as well as free-standing installations.

Hence, they have been involved in many superlatives: the construction of the Burj Khalifa or in New York City, where two high-rise apartment blocks were built alongside the cathedral of St. John the Devine. The distance of the new 430 apartments to the fourth-largest Christian church in the world is between 12 and 0 meters, and as such called for extraordinary solutions. Using the self-climbing RS 850 tubular column system from Putzmeister, which is mounted on a manageable 1 x 1 m, a height of 140 meters was effortlessly overcome and 17.000 m³ of concrete flexibly placed.

Conclusion: MX stationary booms are designed for all areas of the extensive industrial and high-rise construction sites, which are technically difficult to access.

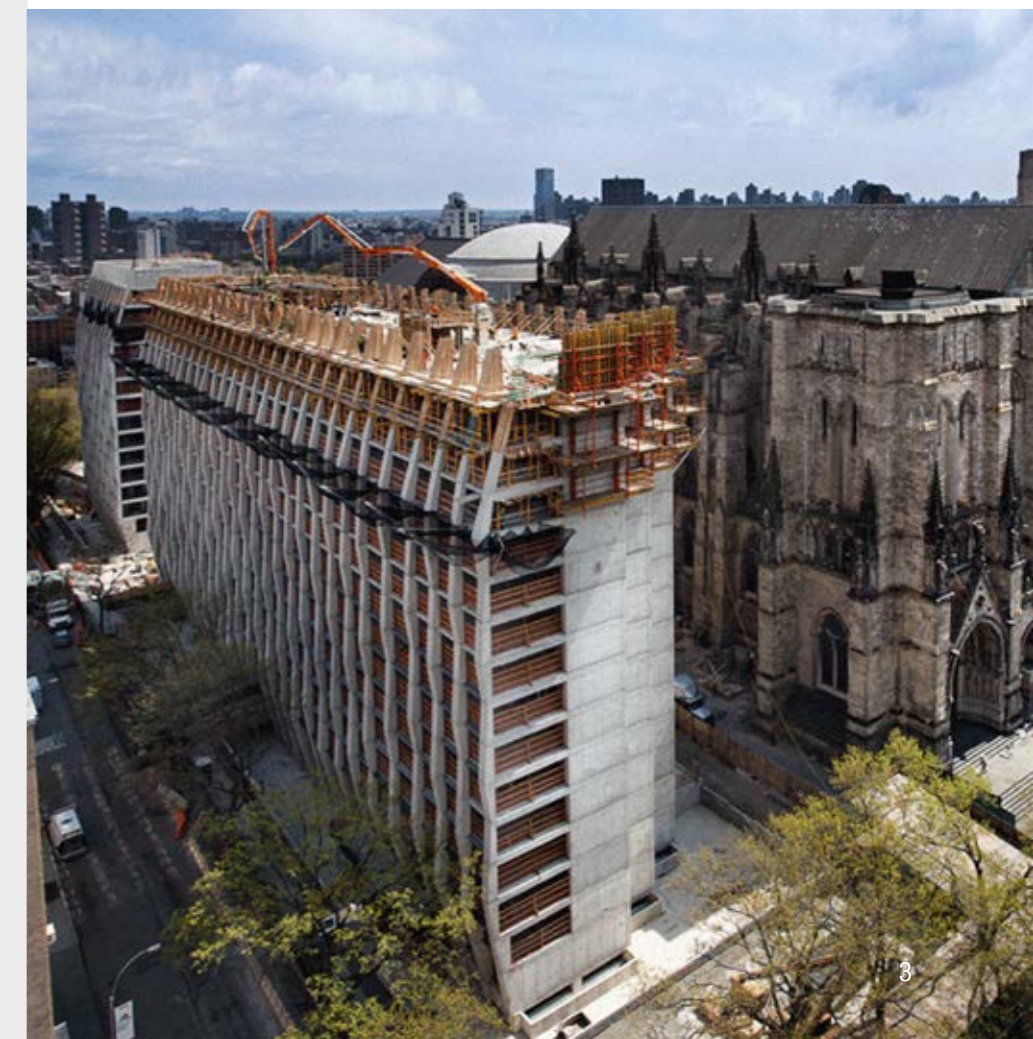

Insertion and distribution

Having the right balance



The MX system – optimum ratio of set up time and performance

The comprehensive, modular range of MX stationary booms offer differing reaches on the Putzmeister RS-850 tubular column system or on lattice towers of reputable manufacturers. Outriggers which, thanks to the quick disconnection system, can be moved in the shortest possible time from the truck-mounted concrete pump to the tubular column and from there to the next one, allow an extreme amount of leeway both aloft and at surface level. Up to a reach of 36 m, they do not require counter ballast, despite of a permissible free-standing height of up to 20 m.

Stationary concrete pumps - high capacity, extremely efficient

Our comprehensive range of stationary concrete pumps offers the right solution for every application. The fully-developed pumps have already proven their convenient operability, reliability and durability in numerous extreme applications. So they rightly enjoy an excellent reputation on the market. This is not least down to the clever coordination of all components such as drive, long-stroke piston pump, free-flowing hydraulics (FFH), S transfer tube and electronic control EPS (Ergonic® Pump System).

Advantages of stationary concrete pumps

- **Particularly robust and wear-resistant**
- **A complete concrete pump for high-rise construction in conjunction with the MX boom**
- **Powerful performance for the high-rise and long-distance pumping of concrete (as powerful as truck-mounted concrete pumps)**
- **Small set-up area required**
- **Available with diesel and electric motors**
- **Extensive, practically-orientated standard equipment and functional accessories**

Additional brochure: Delivery line system PM 2300
BSA- Innovation for clean air BP 4614
BSA Stationary Concrete Pumps BB 2632

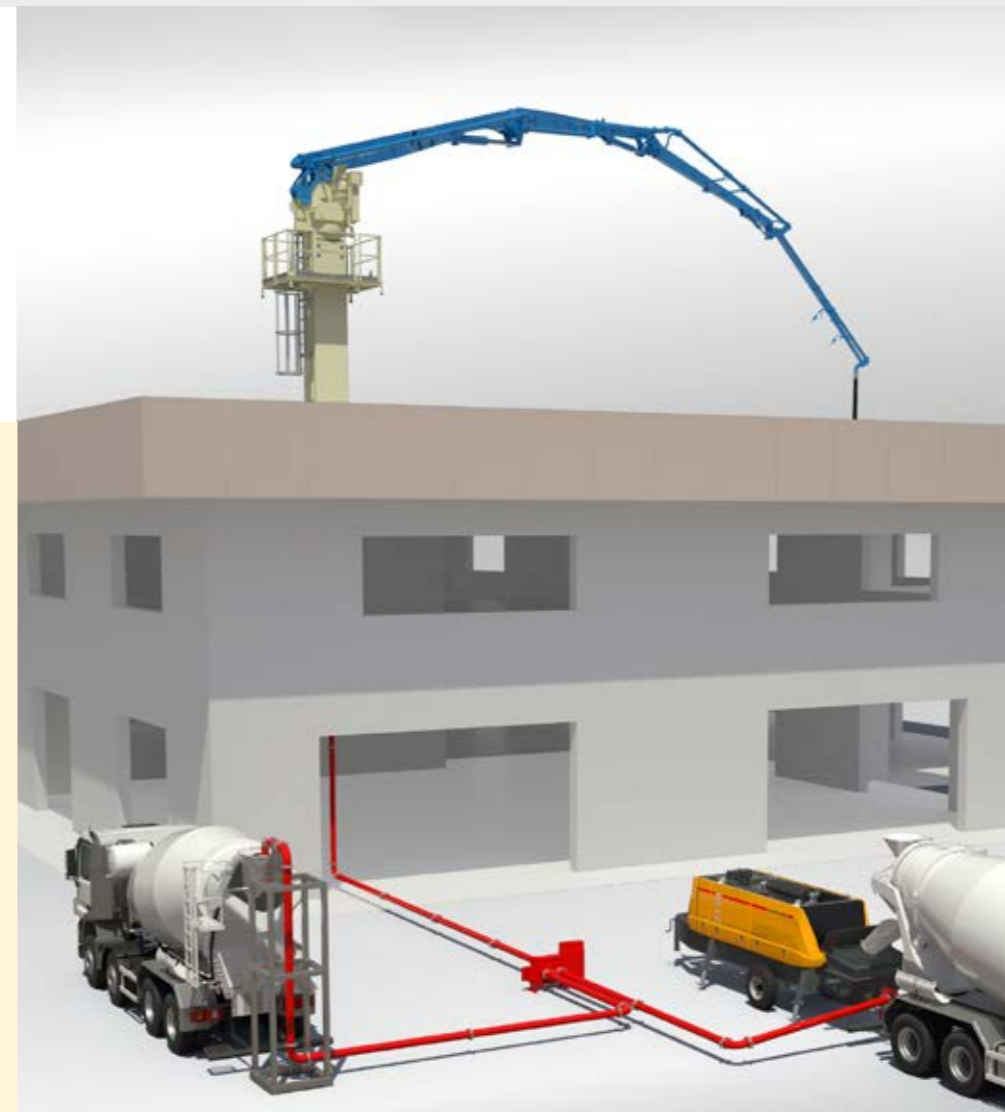

MX boom at a glance

Type	Delivery line Pipe - DN (mm)	End hose max. (m)	Max. height without counterweight (m)	Arms	Folding	Reach (m)	Quick disconnection point
MXR 24-4	125	4	25.5	4	Z	23.8	–
MXR 32-4	125	4	19.5	4	Z	31.8	–
MXR 36-4 Multi	117	3	19.5	4	Z	35.1	Multi
MXG 42-5*	125	4	–	5	RZ	42.1	–
MXG 50-4*	125	3	–	4	R	49.9	–

Standard product construction on square tubular column RS 850, also possible on lattice tower. MXG 42-5 and MXG 50-4 only possible with lattice towers.

* Upon request

High-rise applications



Picture source: Doka GmbH, Amstetten

The perfect combination

In partnership with the customer and the formwork manufacturer, Putzmeister creates a perfect concreting concept. The ideal combination of formwork and placing boom is individually defined for each project. A MX boom can be inserted into the self-climbing formwork or into a self-climbing formwork platform. The self-climbing formwork is often used for pre-running cores.

Picture source: PERI GmbH, Weissenhorn



Climber with the highest cost-efficiency

Self-climbing formworks offer numerous advantages. Maximum safety for construction site personnel and high cost-efficiency. Putzmeister produces for the formwork manufacturer, for example, all necessary calculations and layouts such as the load torque calculation.

If the stationary boom is integrated into self-climbing formwork, it is raised together with the complete formwork by a powerful hydraulic cylinder in a single stroke into the next section to be concreted.

Self-climbing formwork at a glance

- **Maximum safety** for the entire construction site
- **Fast working times** due to quickshuttering times
- **Placing boom integrated into the formwork**

Picture source: Doka GmbH, Amstetten

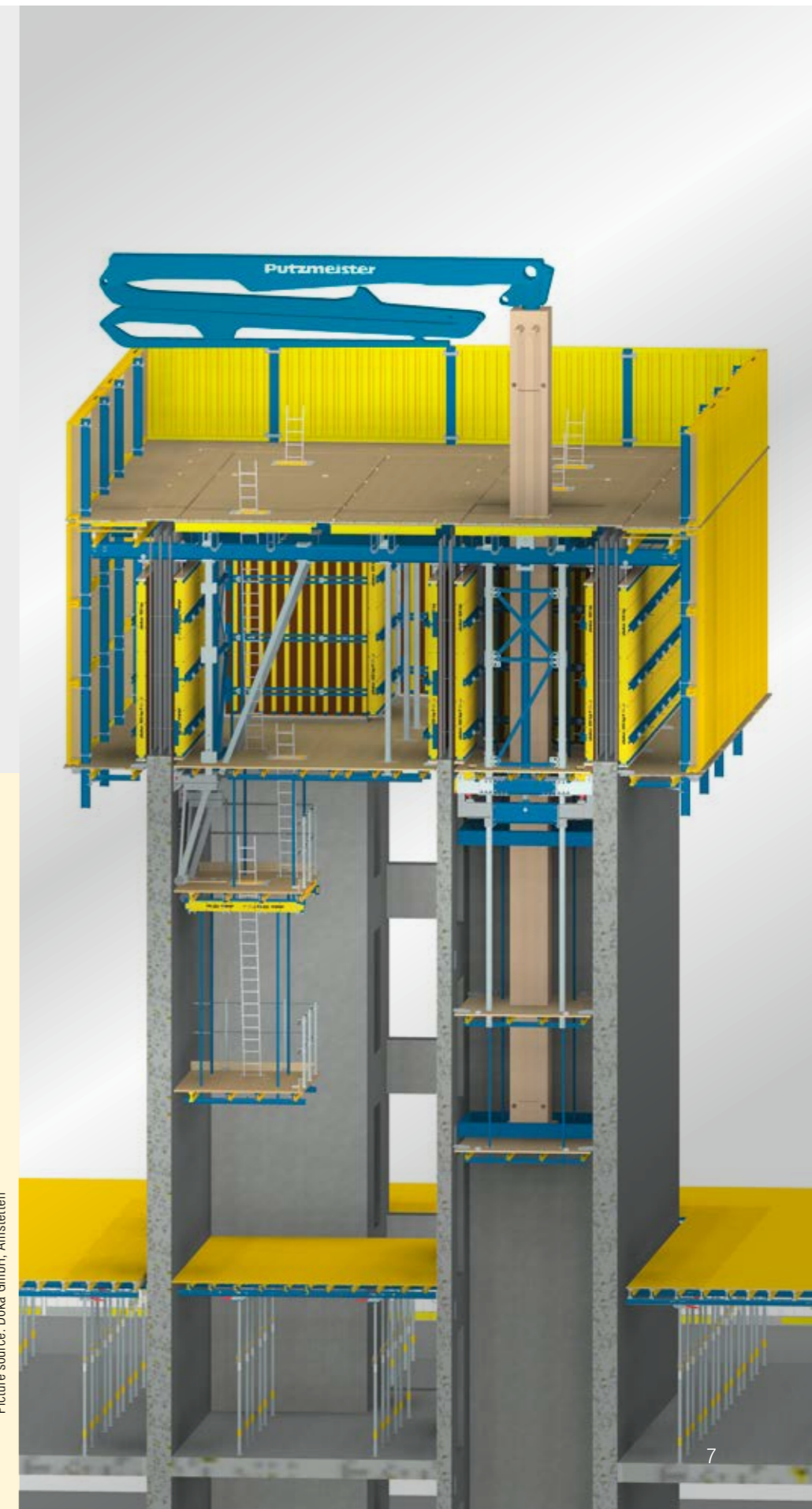

Infrastructure application

Competent teamwork for all applications

Building the Nant de Drance power station in the Valais Alps, for example. Numerous Putzmeister machines were used for 17 km of tunnels with 1.7 million m³ of rubble. 5 stationary concrete pumps conveyed some 360 000 m³ of concrete using two MX 32-4 placing booms. The Putzmeister engineers had developed the concept for the concreting.



Energy application



The system for the (sometimes) marked difference in size

MX stationary booms can be mounted on lattice towers of other renowned manufacturers.* This system is used predominately where a project calls for large reaches. So they can be seen, for example, in the construction of reservoir dams, power stations and liquid gas tanks. Or at widely extending construction sites, such as when building underground railways and stations.

Systematic to a successful implementation

Consistent planning is a crucial success factor. And so Putzmeister engineers create a precise set-up plan in close collaboration with all project participants. Depending on the area to be concreted and the amount of concrete to be placed, the locations of the large booms are planned taking into account maximum reach and height, amongst other factors. This gives the sequence in which and the frequency at which the booms must be moved.

* Technical clarification and approval from Putzmeister required.

Benefits of lattice tower systems at a glance

- **Anchoring** at structure for quick, freestanding mounting
- **Pipelines are laid in the lattice tower, saving space**
- **The rapid separation** device between the boom pedestal and the lattice tower adapter allows the placing boom to be quickly set-up and dismantled

The RS-850 tubular column system the upward trend

Step by step right to the top

The RS-850 tubular column system provides, as standard, columns in lengths of 1.5 m, 3 m, 6 m, 9 m or 10.5 m including the piping with DN 125 concrete delivery lines. This makes parts replacement very uncomplicated. The erection of the boom pedestal* and the arm assembly is carried out on the identical column sections, as for the sub-structure. Consequently, there is no need for special parts. Thanks to the practical double M tubular column profile, a simple quadratic opening of 1 x 1 m is required in the ceilings in order to reach the next floor.

* Putzmeister placing boom from the RS-750 system can be readily combined with the RS-850 tubular column system. Putzmeister offers an adapter for this purpose. So you can use all the benefits of the system with your existing arm assembly.

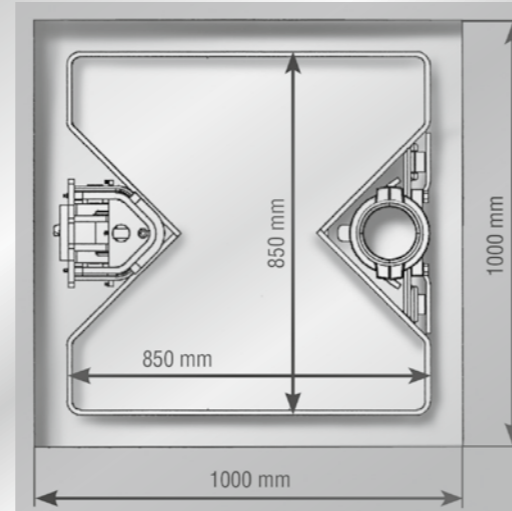

Safety details that later latch into

Safety devices should also satisfy practical aspects. They must be quick to attach and be as compact as possible for transportation. For this reason we have split the working platform. One part can be pre-mounted on the tubular column for the construction site, while the other can be delivered separately and only needs to be latched in and secured.

An optional intermediate working platform, which is mandatory in certain countries, can likewise be readily attached to the tubular column in the shortest time. In addition, ladder elements can be attached to the tubular columns. The safety back protection is removable to prevent it from becoming damaged while being transported or stored.

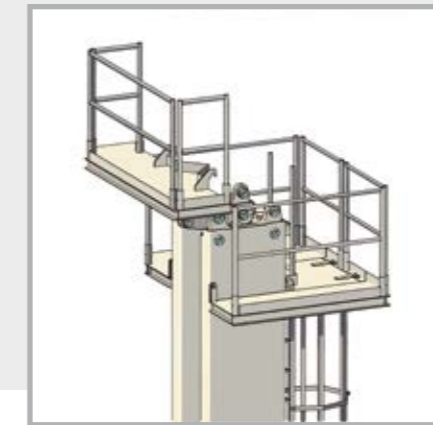

Set-up of a MX boom with the optional safety working platform

- 1 Climbing bar
- 2 Catch for upper climbing carriage
- 3 Upper climbing carriage
- 4 Climbing cylinder

- 5 Lower climbing carriage
- 6 Catch for lower climbing carriage
- 7 Swivel claw
- 8 Extending feet

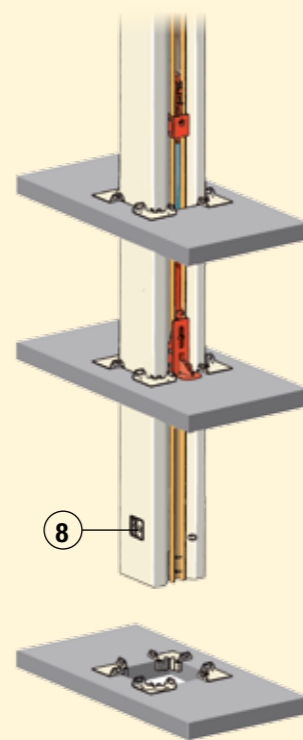
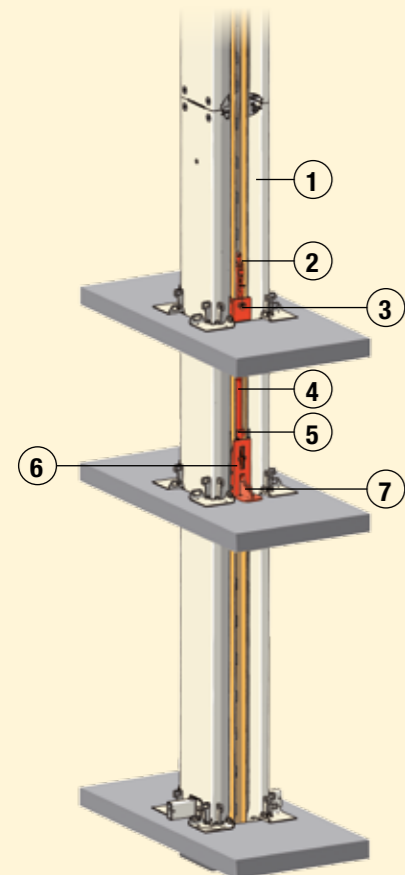

When climbing starts, the swing claw holds the placing boom up, while the lifting cylinder retracts for the next lift.

The column that goes on and through the ceiling itself

Crane capacities on the construction site are in short supply. The MX boom from Putzmeister helps in this regard as it climbs automatically - via a lift cylinder. The Tubular columns in standard lengths 1.5 m, 3 m, 6 m, 9 m and 10.5 m Automatic climbing process with hydraulic climbing device hydraulically driven climbing device integrated in the tubular column profile, pushes the tubular column gradually upwards. At the same time, the delivery line mounted on the tubular column climbs too. Additional pipes can now be conveniently joined at the column end, while the tubular column can be supported after each climb by the so-called extending feet. When a process is completed, it can be repeated as often as required by pulling the climbing cylinder upwards by a cable winch along the rail. This method enables the climbing device to climb automatically through several floors in a building.

The RS-850 system

- **Tubular columns** in standard lengths 1.5 m, 3 m, 6 m, 9 m and 10.5 m
- **Automatic climbing process** with hydraulic climbing device
- **Extending feet** keep the tubular column secure on the slab
- **Simple column** connection using re-usable pins
- **Adapter** between tubular column RS-850 and boom pedestal RS-750 ensures compatibility
- **The structural variants** of the tubular column adapt to each construction site
- **Quick disconnection system** for improved transportation and quick set-up of the outrigger
- **Separable working platform** for ease of transport
- **Climbing columns are available as 10.5 m or 1.5 m elements** for high-rise projects with self-climbing device

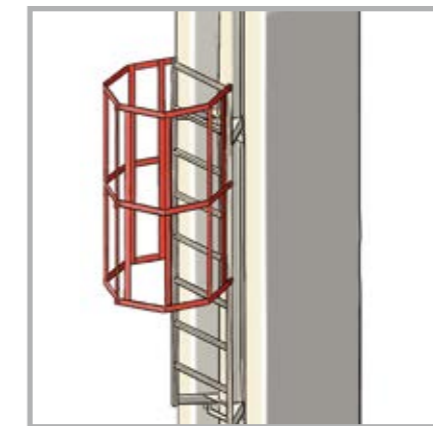

Ladder element with removable back protection



Tubular column with slab guide



Base plates



Slab guide with wedge

On a good foundation to aim high

The tubular column can be set up in several different ways depending on the construction site specifications. Either one mounts the freestanding column on a cruciform base with ballast ⁽¹⁾ or with anchor bolts ⁽²⁾, which are attached to the base plate. Or alternatively in the case of tight spatial conditions a compact cruciform base with a tie rod basket ⁽³⁾ can be fixed to the base. If a base plate and ceiling are already completed, a cruciform base is no longer required. In this case, the tubular

column is held from 4 base plates ⁽⁴⁾ and ceiling corner brackets in the first ceiling over the base plate. In comparison to the ceiling frame previously used, these are significantly lighter and more compact so that they can be easily carried. The concrete placing boom can also be integrated in a climbing formwork or slipform ⁽⁶⁾ depending on the construction site. Putzmeister has developed successfully implemented solutions through years of close cooperation with well-known inter-

national formwork manufacturers. In special cases the stationary boom can also be attached using an anchoring ⁽⁵⁾ at the structure. It is thus possible to bypass heights up to over 40 m freestanding. If the base is steady, the tubular columns can be placed on top of one another. Instead of a long-winded and time-consuming bolted connection, for the RS-850 system the column parts are secured using reusable pins. They can be inserted and tightened by hand.



Cruciform base with ballast ⁽¹⁾

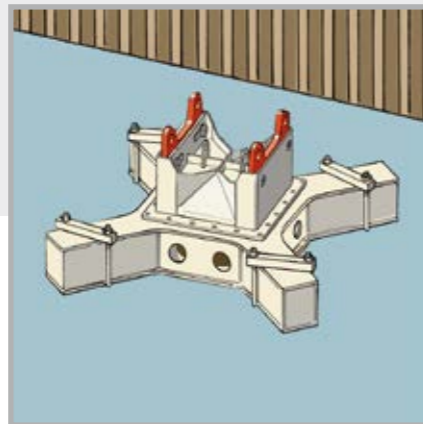

Attached on a base plate with anchors embedded in the foundation ⁽²⁾

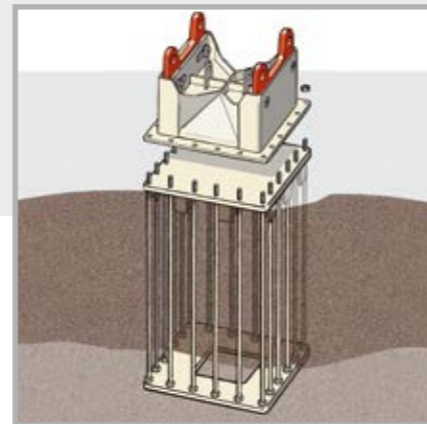

Compact cruciform base anchored in the foundation with a tie-rod cage (when space is restricted) ⁽³⁾

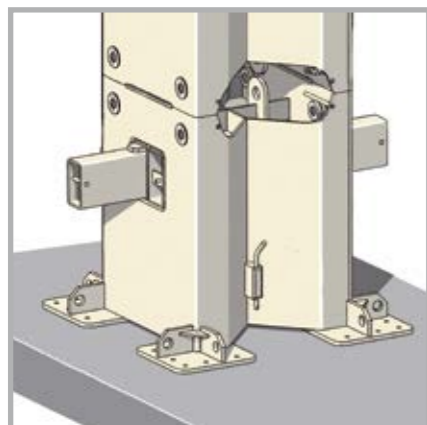

RS-850 with existing base plate and slab fixed with four base plates ⁽⁴⁾

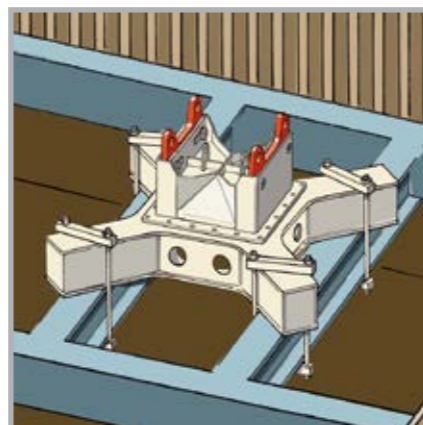

Cruciform base mounted on a shaft frame with tie-rods ⁽⁶⁾

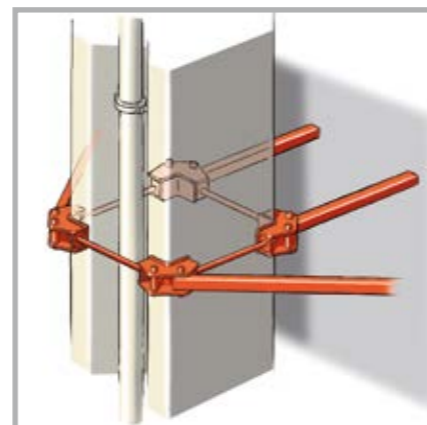

Anchor on the building structure with tie-rods ⁽⁵⁾

The Putzmeister quick disconnection systems allow placing boom to be quickly mounted and dismantled, flexibly relocated and transported more easily. For this reason, we offer the stationary boom MXR 32-4 with G2 disconnection points and the MXR 36-4 with multi-disconnection points.

The G2 joint technology ensures quick and very easy mounting of the MXR 32-4. It can be securely attached with only a few, simple hand grips and is then ready for immediate use.

The MXR 36-4 with multi-disconnection points can be used on truck-mounted concrete pumps as well as tubular columns or lattice towers. At the multi-boom disconnection point, the arm assembly can be removed from the boom pedestal in the shortest time.

The electric motor, all hydraulic components and the boom control are integrated into the boom pedestal.

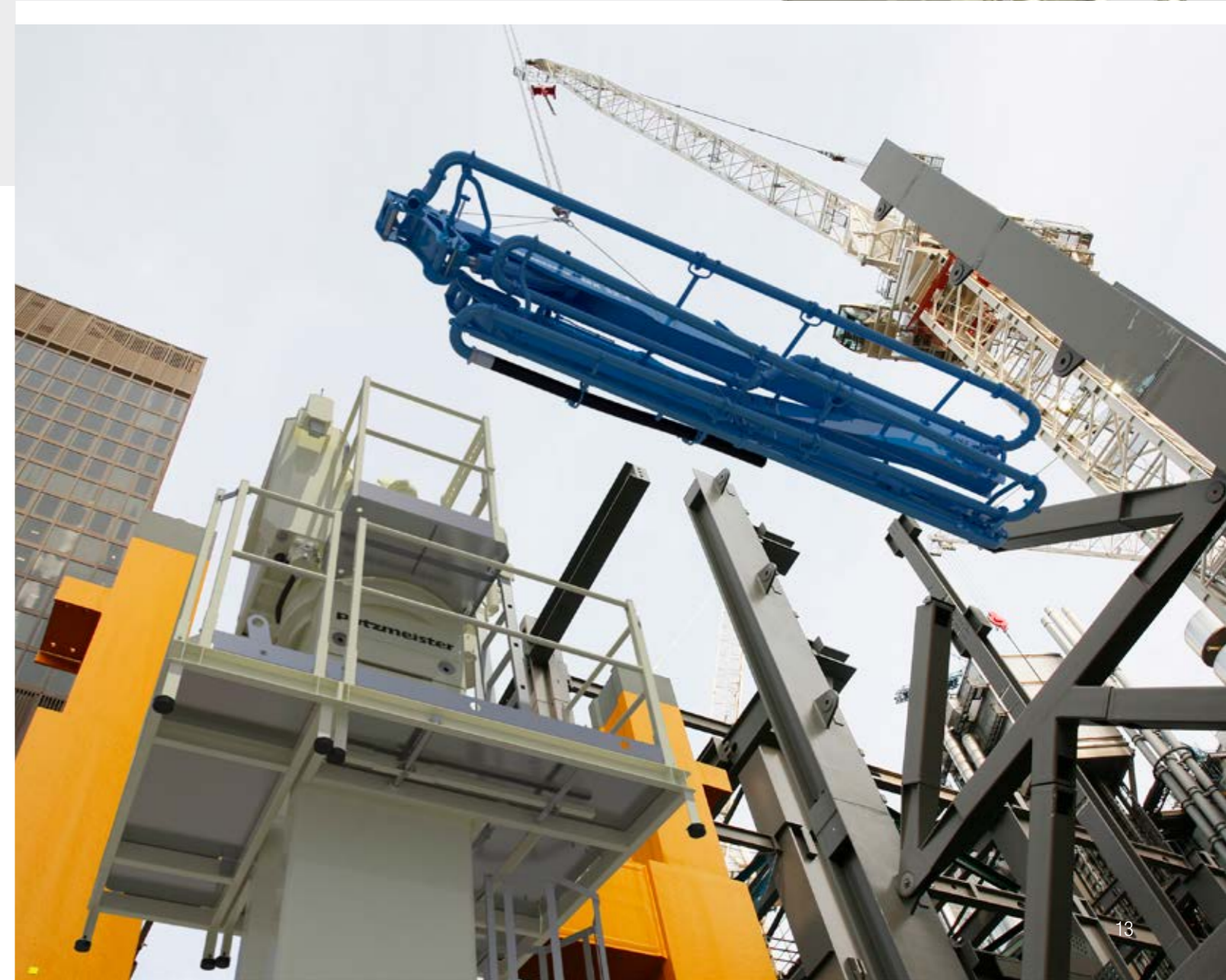

A specialist rarely comes alone

Always the best solution – with the right teaming of lines and pumps

MX stationary booms are out and out team players. Together with stationary concrete pumps and delivery lines from Putzmeister, they ensure the highest efficiency for concrete pumping and placement in every application.



SK standard coupling system

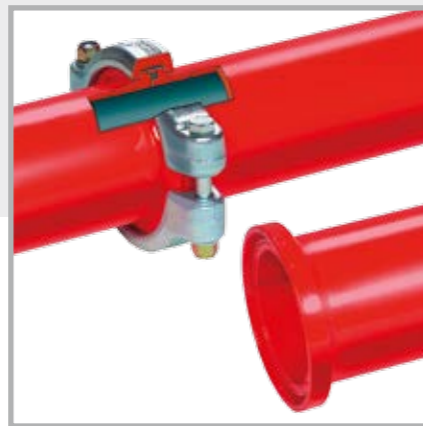

ZX pump delivery system

The SK system

- **Standard delivery lines for placing booms**
- **For pressures to 85 bar in the pumped medium**
- **Special version highly wear-resistant to 130 bar**
- **Axially rotating**

The ZX Zentrifix system

- **Especially suitable for stationary pipeline use**
- **Stable at pressures to 250 bar**
- **Completely leak-proof**
- **Rigid connection between the pipes**
- **Non-axially rotating**

Additional brochure t: Pump line system PM 2300

Transfer tubes and stop valve

In high-rise construction it is very important, with pump pauses or before switching to another pipeline, that the delivery line can be closed off quickly and leak-free. The GV stop valves of the M-series are stopped manually, while the H-series operate hydraulically. DVH transfer tubes permit feeding from a concrete pump from several pump lines.



Stop valve - GVM 2/2



Stop valve - GVMH 2/2

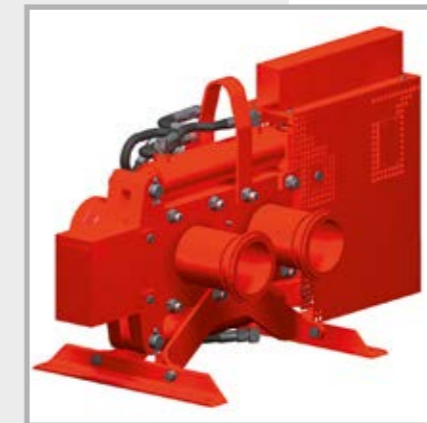

Stop valve - GVH 3/2



Transfer tube – DVH 5/2

Delivery lines for every application

Requirements for delivery lines vary depending on medium, pump and conveying pressures. Putzmeister has delivery lines from the SK and ZX series with fully-developed coupling systems.

SK delivery lines are characterised by flexibility, rotatability of the lines to the coupling stops and a possible displacement of up to 2° in the longitudinal direction.

Typical application areas are high-rise buildings up to approx. 100 m high, long-distance conveying projects up to approx. 500 m and restricted inner city building projects.

ZX delivery lines impress through their leak tightness, high wear resistance, safe operation by a fixed bolting of the coupling and a high pressure resistance. They are used,

for instance, in high-rise concrete pumping to 600 m, such as in the construction of the Burj Khalifa, in long-distance conveying projects up to approx. 2000 m and highly-abrasive concrete grades or concrete that is difficult to pump.



Simply a matter of design – from 24 to 50 m



Picture source: Doka GmbH, Amstetten

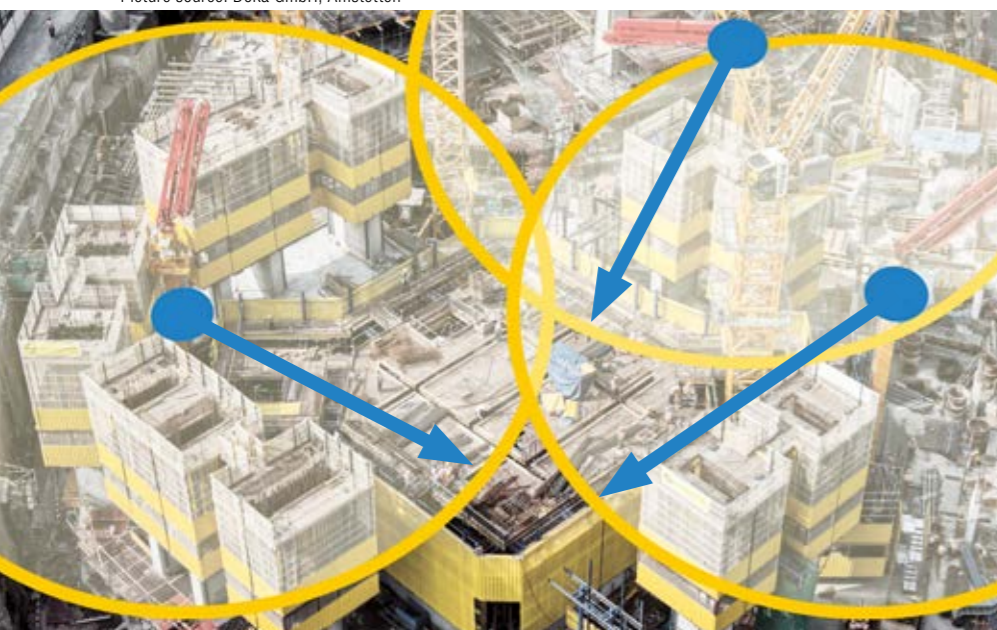

Picture source: Doka GmbH, Amstetten

Multiplicity for the ideal concreting concept

You can plan better with our comprehensive range of MX stationary booms. Whether several booms with reduced reach or better a large boom - this depends on your application range. Single fixed mounting permits a boom with long reach, high conveying quantities to distribute over enormous areas.

Less range, therefore more flexibility

Outrigger with less reach which, due to the quick disconnection system, can be moved in the shortest possible time, offers extreme flexibility, not only in height but at surface level. It should also be noted considered that no counter ballast is required up to a reach of 36 m. The reduced space requirements also make working easier, particularly up through ceilings or shafts.

MXR 24-4

Pedestal	RS pump line
Delivery line pipe	133 × 4 mm
Delivery line DN	125/5.5"
Arm, folding	4Z
Reach	23.8 m
Reach depth	20.9 m
End hose length	4 m
Swivelrange	365°
Boom weight	3.9 t
Pedestal weight	2.1 t

All data represents theoretical maximum values. Dimensions configuration-dependent.



Length 7 990 mm
Width 2 522 mm
Height 2 515 mm

MXR 32-4

Pedestal	RS
quick disconnection point	G2
Delivery line pipe	133 × 4 mm
Delivery line DN	125/5.5"
Arm, folding	4Z
Reach	31.8 m
Reach depth	28.8 m
End hose length	4 m
Swivelrange	365°
Boom weight	4.9 t
Pedestal weight	2.2 t

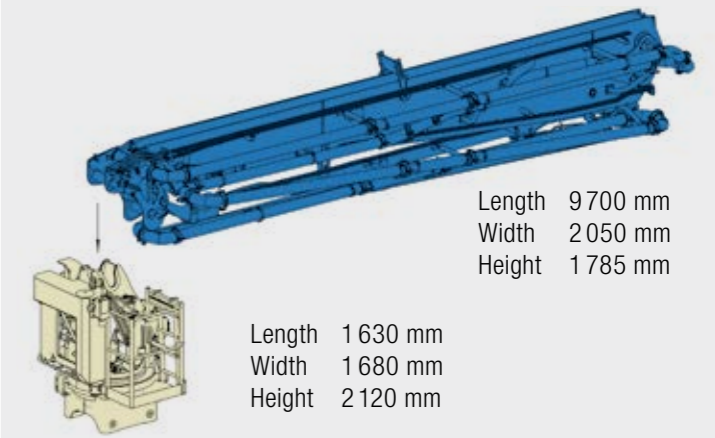

Length 9 700 mm
Width 2 050 mm
Height 1 785 mm

Length 1 630 mm
Width 1 680 mm
Height 2 120 mm

MXR 36-4 Multi

Pedestal	RS
quick disconnection point	Multi
Delivery line pipe/with coupling	133 × 4 mm/55 mm
Delivery line DN	117/5.5"
Arm, folding	4Z
Reach	35.1 m
Reach depth	28.6 m
End hose length	3 m
Swivelrange	365°
Boom weight	6.2 t
Pedestal weight	2.7 t

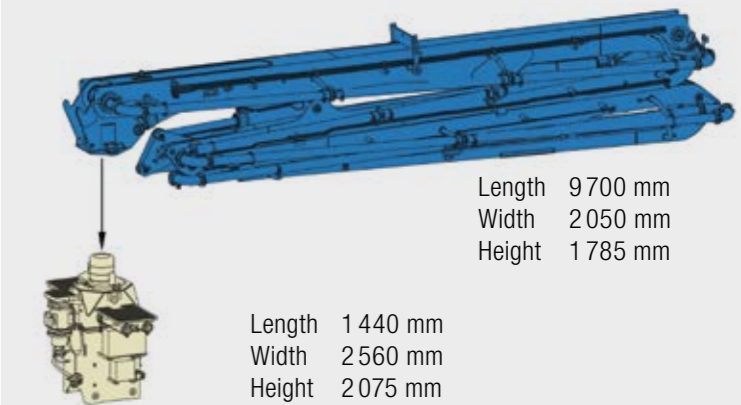

Length 9 700 mm
Width 2 050 mm
Height 1 785 mm

Length 1 440 mm
Width 2 560 mm
Height 2 075 mm

MXG 42-5

Pedestal	G
Delivery line pipe/with coupling	133 × 4 mm/55 mm
Delivery line DN	125
Arm, folding	5RZ
Reach	42 m
Reach depth	32 m
End hose length	4 m
Swivelrange	365°
Boom and pedestal weight	13 t

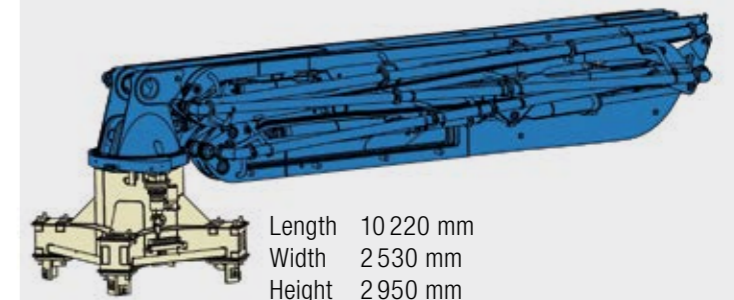

Length 10 220 mm
Width 2 530 mm
Height 2 950 mm

MXG 50-4

Pedestal	G
Delivery line pipe/with coupling	133 × 4 mm/55 mm
Delivery line DN	125/5.5"
Arm, folding	4R
Reach	49.9 m
Reach depth	39.2 m
End hose length	3 m
Swivelrange	365°
Boom weight	8 t
Main carrier weight	9.5 t
Ballast carrier weight	2.4 t
Counterweight	16 t

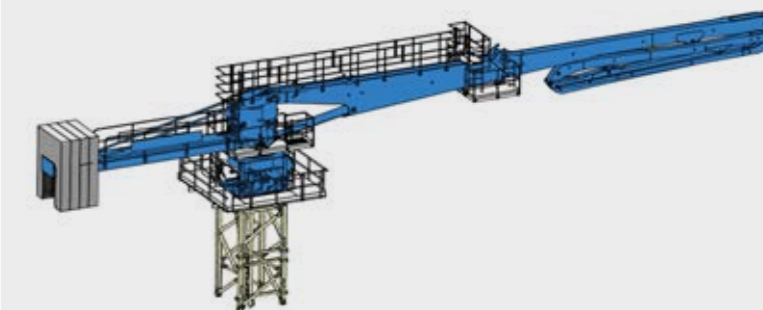

All data represents theoretical maximum values. Dimensions configuration-dependent.

Build on Putzmeister – in service, parts, training

Everything that sets service apart

Swift assistance, meaningful advice and a reliable supply of genuine Putzmeister accessories and parts - in over 120 countries worldwide. This is what we at Putzmeister understand as first-class service.

Ideally placed to support you

We train our service technicians continuously, provide a close-knit information network and the latest equipment and consistently strive to meet our customers' needs.

Thanks to state-of-the-art technology, our employees have all the relevant technical information about your machine at their fingertips, should the need arise. Allowing us to provide you with the best possible support for emergencies, repairs or preventive maintenance.



Genuine parts for maximum availability

It goes without saying that we use only genuine Putzmeister parts in our workshops. This is the only way to guarantee consistent quality, checked for interoperability. And you can be absolutely sure that your machine meets the tough requirements with maximum performance and availability.

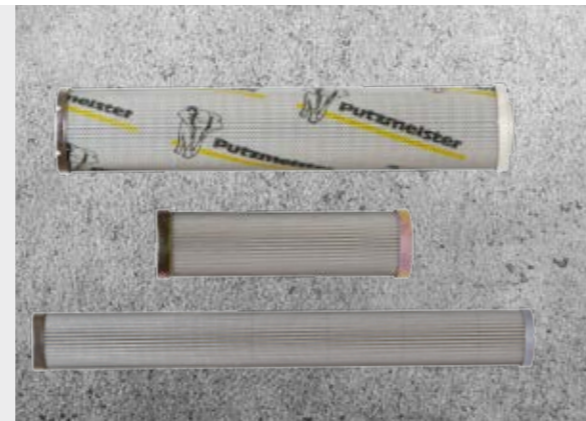

Excellent in quality and customer proximity

In case of need, you have two options: Either the service team visits you or you take your machine to one of our service workshops. The latest tools, software analysis solutions and genuine parts ensure that your machine is operable again immediately.

All Putzmeister workshops and the workshops of our international Putzmeister partners meet our high-quality standard. Especially when it comes to manufacturer's inspections and acceptance procedures in accordance with specifications.

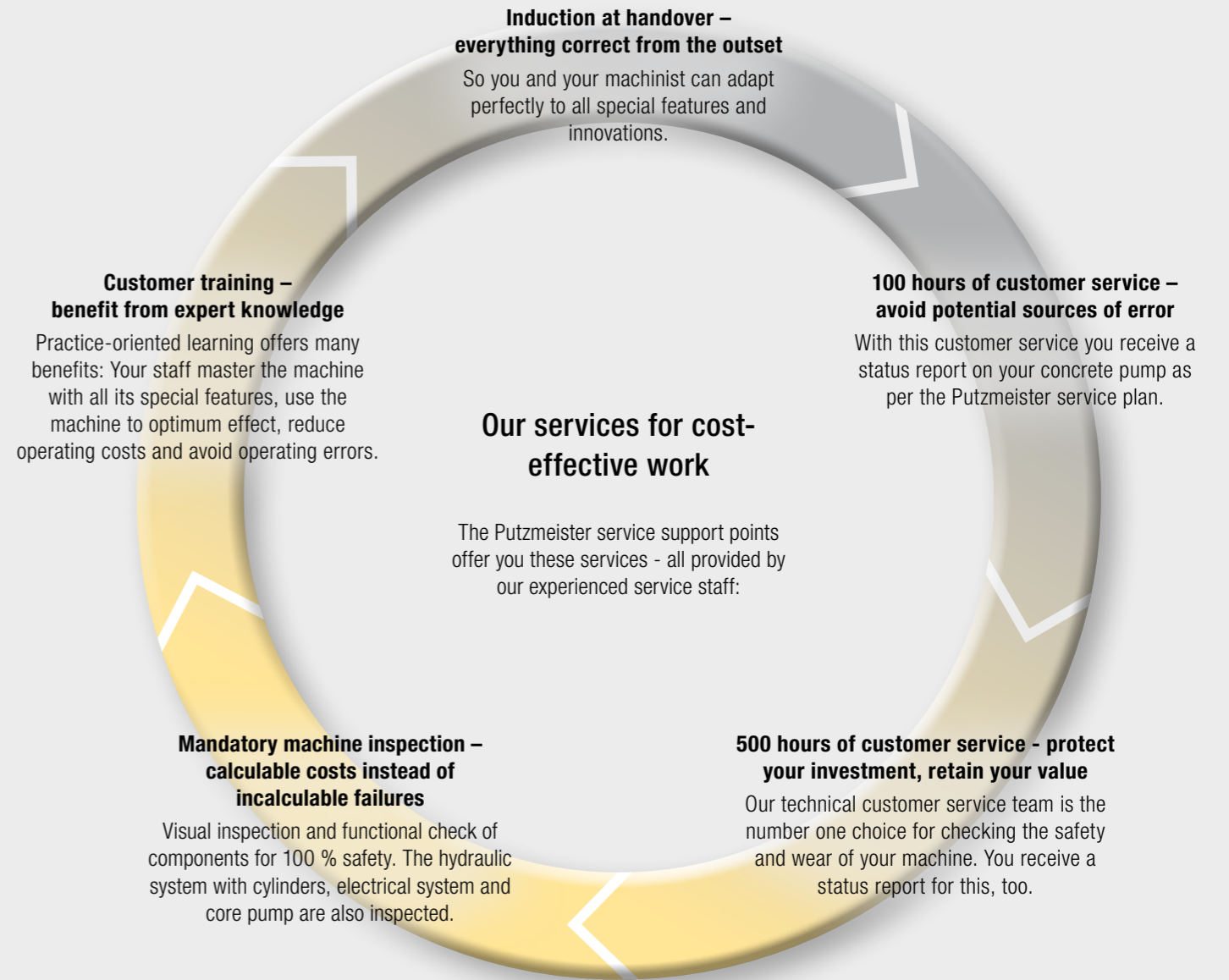

Our range of training courses and seminars:

For concrete pump operators

- Training and development seminars on concrete pumps
- Training and development seminars on PUMI with piston and rotor pumps
- Regional/company seminars (in your region or on your premises)

For concrete pump mechanics

- Training and development seminars on concrete pump

For concrete pump machinists and mechanics

- Practical days in Aichtal
- Training: Handover and induction, on-the-job training

For workshop managers and foremen

- Overview of current developments in Putzmeister concrete pumps
- Qualification at the customer workshops for requisite maintenance work

Further information can be found at: www.pm-akademie.de

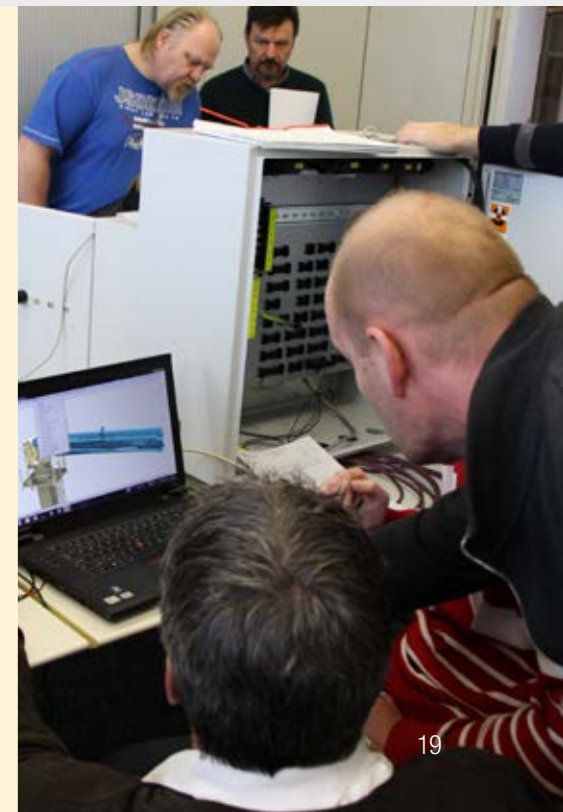

The key benefits at a glance

MX stationary boom

- **With or without counterweight***
- **Convenient transport and assembly** as well as minimum set-up times through quick disconnection devices
- **Secure handling**
- **Many mounting and attachment variants** on the base plate, building or on a climbing formwork adapt to every construction site situation
- **Automatic climbing** process with hydraulic climbing device allows the boom to grow to the heights with the building
- **Reduced space requirement**
- **Remote control via cable or radio** allows precise and convenient operation
- **Single, 1 m²quadratic floor opening** suffices for floor access way
- **Low-maintenance components**

* Only 36 m reach without counterweight permissible, optional dependent on the configuration

RS-850 system

- **Tubular columns in standard lengths 1.5 m, 3 m, 6 m, 9 m and 10.5 m**
- **Climbing columns as 10.5 m or as 1.5 m elements** for high-rise building projects with self-climbing device available
- **Extending** feet keep the tubular column secure on the slab
- **Simple column connection** using pins, which are inserted manually, ensure quick assembly
- **Adapter between tubular column RS-850 and boom pedestal R-750** ensures compatibility with the predecessor model
- **Divisible working platform** for easier transport and safe mounting

Further brochures: Ergonic® CT 4690
Stationary concrete pumps CT 2632
Pump line system PM 2300



Putzmeister Concrete Pumps GmbH

Max-Eyth-Straße 10 · 72631 Aichtal / Germany
P.O.Box 2152 · 72629 Aichtal / Germany
Tel. +49 (7127) 599-0 · Fax +49 (7127) 599-520
pmw@pmw.de · www.putzmeister.com

